

Influence of Organizational Culture and Leader's Engagement on Leadership Performance in Open Online Flexible Distance Learning Higher Education Institutions

Zahir Osman, Ratna Khuzaimah Mohamad, Nadzurah Kasbun

Open University Malaysia

Email: Ratna_mohamad@oum.edu.my, nadzurahkasbun@oum.edu.my

Corresponding Author Email: zahir_osman@oum.edu.my

To Link this Article: <http://dx.doi.org/10.6007/IJAREMS/v13-i3/22006>

DOI:10.6007/IJAREMS/v13-i3/22006

Published Online: 09 July 2024

Abstract

This study delves into the critical role of leadership performance in higher education institutions, recognizing its multifaceted importance in shaping organizational effectiveness and success. Drawing upon the Transformational Leadership Theory, the study aims to explore the direct and indirect relationships between organizational culture, leader engagement, leader's self-efficacy, and leadership performance, with a focus on open online flexible distance learning higher education institutions. Employing a survey-based approach, data was collected from a sample of 342 participants using purposive sampling. Structural equation modeling (SEM) was utilized for data analysis, with Smartpls4 software employed for its proficiency in handling multivariate data analysis. Results indicate significant direct and indirect relationships between leader engagement, self-efficacy, organizational culture, and leadership performance. Leader engagement positively influences leadership performance, with self-efficacy mediating this relationship. Organizational culture significantly influences both leader self-efficacy and leadership performance, with self-efficacy partially mediating the relationship between culture and performance. Theoretical implications underscore the significance of transformational leadership theory in understanding leadership dynamics in distance learning environments. Practical implications highlight the importance of fostering a positive organizational culture, enhancing leader engagement, and promoting transparency and communication for effective leadership. Contextual implications emphasize the need for adaptable leadership approaches in online learning settings. Suggestions for future research include exploring specific leadership styles, conducting longitudinal studies on leadership development interventions, investigating the influence of external factors on leadership dynamics, and conducting comparative studies on cross-cultural variations in leadership practices. Overall, the study offers valuable insights for policymakers, institutions, and employees in enhancing leadership effectiveness and organizational performance in open online flexible distance learning higher education institutions.

Keywords: Leader's Engagement, Leader's Self-efficacy, Organizational Culture, Leadership

Performance

Introduction

Leader performance in higher education institutions plays a pivotal role in shaping these academic settings' organizational effectiveness and success. The importance of a leader's performance in higher education institutions is multifaceted (Tyagi, 2021). Effective leadership is crucial for fostering a positive organizational culture, driving innovation, ensuring strategic decision-making, and ultimately enhancing the overall performance and reputation of the institution (Akanji et al., 2020). Leaders in higher education institutions must navigate complex challenges such as technological advancements, changing student demographics, and evolving educational paradigms. This requires leaders who can inspire change, promote collaboration, and adapt to the dynamic landscape of higher education (Hidayat et al., 2020). Despite advancements in understanding leadership in higher education, research gaps exist in leader's performance (Kebah et al., 2019). One notable gap is the need for more studies that explore the specific impact of leadership styles on organizational outcomes within higher education institutions (Afrifa et al., 2022). This includes understanding how different leadership styles influence factors such as employee job satisfaction, commitment, and overall performance. Additionally, there is a growing need for research that delves into the role of leadership in addressing issues of diversity, equity, and inclusion within academic settings (Rohman et al., 2021). Understanding how leadership practices can foster a more inclusive and supportive environment is crucial for the holistic development of higher education institutions (Nwannah et al., 2022). The significance of studying leader performance in higher education institutions extends to policymakers, the institutions themselves, and employees. Policymakers can benefit from research in this area to inform policies that support effective leadership development programs within higher education (Kebah et al., 2019). Institutions can use insights from such studies to enhance leadership training, succession planning, and organizational performance. For employees, understanding the impact of leadership on their work environment can lead to improved job satisfaction, motivation, and overall well-being within the academic community. Moreover, research on leader performance can contribute to the development of evidence-based best practices that can be shared among higher education institutions globally, fostering a culture of continuous improvement and excellence (Insan & Masmarulan, 2021). Another important aspect of leader performance in higher education institutions is the role of vision and performance. There is a critical gap in educational leadership research regarding the relationship between vision components and the performance of higher education institutions (Srimulyani & Hermanto, 2022). Developing a research model to examine these relationships can provide valuable insights into effective leadership practices. Additionally, the role of organizational justice in leadership and performance in higher education institutions is an area that requires further research (Khan et al., 2020). Understanding how leaders can promote fairness and justice within their institutions can contribute to improved organizational performance and employee satisfaction. Furthermore, research is needed to explore the effectiveness of leadership development programs within higher education institutions (Lasrado & Kassem, 2021). This includes understanding how these programs can enhance leadership skills and improve organizational performance. By addressing these research gaps, we can gain a more comprehensive understanding of leader performance in higher education institutions, leading to the development of evidence-based best practices that can be shared globally, ultimately fostering a culture of continuous improvement and

excellence in higher education (Kaur & Poh, 2022). This study aims to assess the direct and indirect relationship between organizational culture, leader's engagement, and leader's performance with the leader's self-efficacy as a mediator in open online flexible distance learning higher education institutions.

Literature Review

Underpinning Theory

The Transformational Leadership Theory Bass & Riggio (2006) provides a strong theoretical foundation for studying the influence of organizational culture and leader's engagement on leadership performance in open online flexible distance learning higher education institutions, with the role of the leader's self-efficacy as a mediator. Transformational leadership is characterized by leaders who inspire and motivate followers to achieve common goals, encourage innovation and creativity, and foster a positive work environment. This aligns well with the study's focus on understanding how leaders can shape organizational culture and enhance their engagement to improve leadership performance in the context of higher education institutions (Burns, 2012). Transformational leaders establish organizational norms that promote follower initiative, achievement-oriented behaviors, and goal attainment. By articulating a compelling vision, communicating it effectively, and inspiring followers to share in the vision, transformational leaders can create a positive culture that fosters creativity, innovation, and collaboration. Moreover, the Transformational Leadership Theory emphasizes the importance of leaders developing their communication, motivation, and team-building skills to inspire their followers (Bass, 1999). This is particularly relevant in the context of open online flexible distance learning, where leaders must navigate complex challenges and adapt to changing circumstances. The theory also highlights the role of a leader's self-efficacy, which refers to an individual's belief in their ability to perform a specific task or behavior. By enhancing their self-efficacy, leaders can become more confident and effective in their roles, ultimately improving their performance and positively influencing organizational culture and employee engagement.

Relationship between Leadership Engagement, Leader's Self-Efficacy and Leadership Performance

The relationship between leadership engagement and leadership performance is significantly influenced by a leader's self-efficacy, which serves as a mediator. Leader self-efficacy refers to an individual's confidence in their ability to lead effectively, and it plays a crucial role in shaping their engagement and performance (Rabiul et al., 2022). Research has consistently shown that leaders with high self-efficacy are more likely to be engaged in their roles and exhibit effective leadership behaviors, leading to improved organizational performance (Ul Hassan & Ikramullah, 2024). When leaders are confident in their abilities, they are more likely to take on challenging tasks, set goals, and persist in the face of obstacles (Mulyanti et al., 2023). This increased engagement and motivation lead to enhanced performance, as leaders are better equipped to handle complex tasks and make informed decisions (Asfaq et al., 2021). Moreover, high self-efficacy leaders are more likely to inspire and motivate their followers, fostering a positive work environment and promoting collective success (Seo & Kwon, 2020). The mediating role of self-efficacy is evident in studies that have found that leader self-efficacy positively affects work engagement, which in turn enhances performance (Zeeshan et al., 2021). For instance, a study on the relationship between leadership style and employee performance found that leaders with high self-efficacy were more likely to exhibit

transformational leadership behaviors, leading to improved employee performance (Liou & Daly, 2020). Similarly, research on the impact of leadership self-efficacy on performance found that leaders with high self-efficacy were more likely to engage in behaviors that enhance performance, such as setting goals and persisting in the face of obstacles (Meria et al., 2022). Therefore, the following hypotheses were proposed for this study:

- H1: *There is a relationship between a leader's engagement and leadership performance in open online flexible distance learning higher education institutions*
- H2: *There is a relationship between a leader's engagement and a leader's self-efficacy in open online flexible distance learning higher education institutions*
- H3: *There is a mediating effect of a leader's self-efficacy on the relationship between a leader's engagement and leadership performance in open online flexible distance learning higher education institutions*

Relationship between Organizational Culture, Leader's Self-Efficacy and Leadership Performance

The connection between organizational culture and leadership performance is significantly influenced by the leader's self-efficacy, which acts as a mediator (Osman et al., 2018). Organizational culture refers to the shared values, beliefs, and assumptions that guide individual behavior within an organization (Pratiwi & Nawangsari, 2021). Leader self-efficacy, on the other hand, is an individual's confidence in their ability to lead effectively. When an organization has a strong, positive culture that emphasizes collaboration, innovation, and achievement, leaders are more likely to develop high self-efficacy (Azeem & Hanoum, 2024). This is because they are surrounded by supportive colleagues, have access to resources and opportunities for growth, and are motivated to perform at a high level (Wickneswary et al., 2024). Leaders with high self-efficacy are more likely to exhibit effective leadership behaviors, such as setting clear goals, communicating effectively, and empowering their followers (Supriyatna & Wulandari, 2023). Research has shown that organizational culture positively affects leader self-efficacy, which in turn enhances leadership performance (Li et al., 2020). For example, studies have found that leaders with high self-efficacy are more likely to exhibit transformational leadership behaviors, leading to improved employee performance (Wu et al., 2023). Additionally, research has shown that leaders with high self-efficacy are more likely to engage in behaviors that enhance performance, such as setting goals and persisting in the face of obstacles (Adu & Nawangsari, 2023). The mediating role of self-efficacy is particularly evident in the context of higher education institutions, where leaders must navigate complex challenges and adapt to changing circumstances (Chughtai et al., 2023). In these settings, a positive organizational culture that fosters collaboration, innovation, and achievement can help leaders develop high self-efficacy, enabling them to perform effectively and inspire their followers. (Wonodhipo et al., 2024). Thus, the following hypotheses were proposed for this study:

- H4: *There is a relationship between an organizational culture and leadership performance in open online flexible distance learning higher education institutions*
- H5: *There is a relationship between an organizational culture and a leader's self-efficacy in open online flexible distance learning higher education institutions*
- H6: *There is a relationship between a leader's self-efficacy and leadership performance in open online flexible distance learning higher education institutions*
- H7: *There is a mediating effect of a leader's self-efficacy on the relationship between an*

Organizational culture and leadership performance in open online flexible distance learning higher education institutions

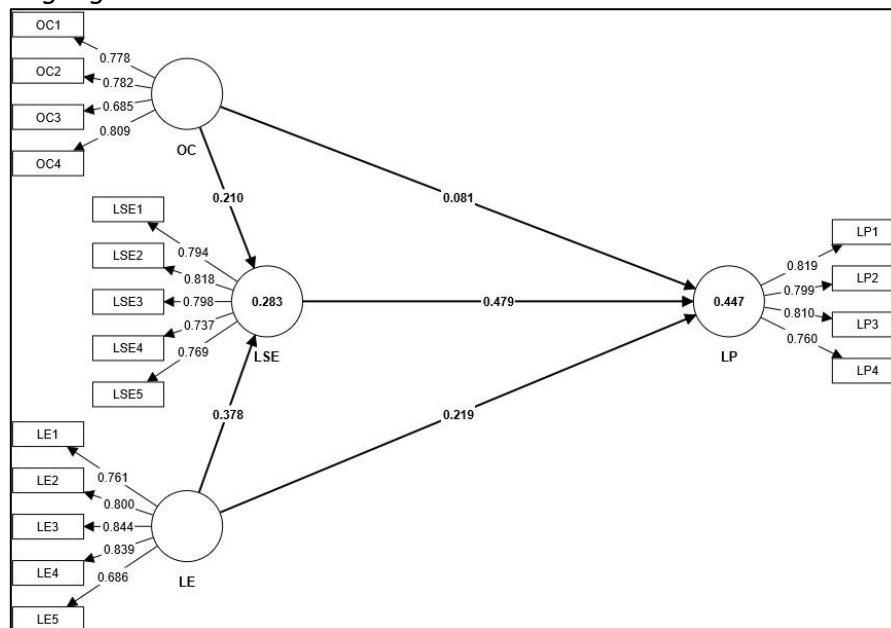

Figure 1: Research Framework

Notes: OC=Organizational Culture LE=Leader’s Engagement LSE=Leader’s Self-Efficacy LP=Leadership Performance

Methodology

This study aimed to comprehensively evaluate the direct and indirect impact of leaders' engagement, leadership style, adaptability, and leaders' performance in open online distance learning higher education institutions, with leaders' self-efficacy as a mediator. To achieve this objective, researchers surveyed participants, meticulously selecting reliable and valid measurements through a thorough examination of previous research. The survey questionnaires were distributed via email to selected participants, employing purposive sampling due to the absence of a comprehensive population list. A total of 18 observed variables were scrutinized, incorporating exogenous variables such as organizational culture, adapted from Van Den Berg (2017) (4 items), and leaders' engagement, adapted from Shuck et al (2017) (5 items). The study's mediating factor was leaders' self-efficacy, drawn from Bobbio & Manganelli (2009) (5 items), while the endogenous variable was leaders' performance, sourced from Bratton & Gold (2017) (4 items). Respondents assessed elements within each construct using a Likert scale with five response options ranging from strongly disagree to strongly agree. Out of 472 surveys distributed, 361 were collected, yielding a satisfactory response rate of 76.5%, conducive for employing structural equation modeling (SEM) in data analysis. Of the collected surveys, 342 were deemed clean and suitable for analysis. Researchers selected Smartpls4 software, known for its proficiency in structural equation modeling (SEM) techniques, for data analysis and hypothesis testing. This choice was influenced by the software's robust assessment capabilities and expertise in managing multivariate data analysis, aligning with the study's objectives and adhering to the recommendations of (Ringle et al., 2022). Smartpls4 facilitated a meticulous evaluation of the proposed hypotheses and conducted extensive multivariate data analysis, enabling a comprehensive assessment of both measurement and structural models.

Data Analysis

Respondents' Profiles

The respondent profiles in this study demonstrate a diverse representation across various demographic characteristics. In terms of gender, the majority of the respondents are male, accounting for 59.9% (205 individuals), while females make up 40.1% (137 individuals) of the total sample. This suggests a slightly higher participation from male leaders in open online distance learning higher education institutions. When examining age distribution, the largest group falls within the 41-50 years old category, comprising 40.6% (139 respondents), followed by the 31-40 years old group at 23.1% (79 respondents) and the 51-60 years old group at 19.9% (68 respondents). The youngest age group (<30 years old) and the oldest age group (>60 years old) have the lowest representation, with 7.6% (26 respondents) and 8.8% (30 respondents), respectively. This indicates that the majority of the leaders in these institutions are middle-aged, with a significant presence of younger and older leaders as well. In terms of years of service, the respondents are fairly evenly distributed across the 11-15 years and 16-20 years categories, each accounting for 30.1% (103 respondents). The 6-10 years and 21-25 years groups follow with 12.6% (43 respondents) and 12.9% (44 respondents), respectively. The <5 years, 26-30 years, and >30 years categories have the lowest representation, ranging from 4.4% to 5.3%. This suggests that the majority of the leaders have substantial experience in their roles, with a smaller proportion of both newer and more seasoned leaders. Finally, the respondents are divided into two main categories based on their position: academicians and non-academicians. Academicians make up the majority, accounting for 57.3% (196 respondents), while non-academicians comprise 42.7% (146 respondents) of the total sample. This indicates that the study has a strong representation of both academic and non-academic leaders in open online distance-learning higher education institutions.

Common Method Bias

Kock (2015); Kock & Lynn (2012) developed a comprehensive methodology for assessing both vertical and horizontal collinearity in structural equation modeling (SEM) using partial least squares (PLS-SEM). This approach, known as the collinearity test, relies on variance inflation factors (VIFs) to identify potential common method bias within a model. The identification of pathological collinearity is contingent upon VIFs exceeding 3.3, indicating a significant concern for common method bias within the model. Conversely, if the VIFs derived from the comprehensive collinearity assessment fall below 3.3, it can be inferred that the model remains unaffected by common method bias (Table 1).

Table 1

Full Collinearity

	LP	OC	LE	LSE
LP		1.749	1.697	1.357
OC	1.615		1.287	1.602
LE	1.728	1.419		1.738
LSE	1.370	1.752	1.723	

Measurement Model

In this study, we followed Hair et al.'s (2017) methodology to assess each measurement in both the first and second orders, aiding in identifying items with loadings below the 0.7 threshold. Our analyses of construct reliability and validity indicated that the Average

Variance Extracted (AVE) for all constructs ranged from 0.585 to 0.636, exceeding the 0.5 benchmark, thus demonstrating robust convergent validity Hair et al (2017) (Table 2). Moreover, the composite reliability for all constructs surpassed 0.7, ranging from 0.849 to 0.891. Additionally, Cronbach's alpha values for all constructs were above 0.7, ranging from 0.762 to 0.848 (Table 2). To ensure discriminant validity, the initial step involved assessing cross-loadings for appropriate representation and measurement of respective constructs (Table 2). Subsequently, we employed the Heterotrait-Monotrait (HTMT) ratio for further evaluation, adhering to the recommended criterion for examining discriminant validity in Variance-Based Structural Equation Modeling (VB-SEM) (Henseler, Ringle & Sarstedt, 2015). Table 2 presented the HTMT ratios, original sample, and 95% confidence intervals, confirming compliance with the HTMT threshold of 0.85.

Table 2

Construct Reliability and Validity, Item Loadings & Hetrotrait-Monotrait Ratios

Constructs	Indicators	Loadings	CA	CR	AVE	LE	(HTMT)	
							LP	LSE
Leader's Engagement	LE1	0.761	0.848	0.891	0.621			
	LE2	0.800						
	LE3	0.844						
	LE4	0.839						
	LE5	0.686						
Leadership Performance	LP1	0.819	0.810	0.875	0.636	0.592		
	LP2	0.799						
	LP3	0.810						
	LP4	0.760						
Leader's Self-Efficacy	LSE1	0.794	0.843	0.888	0.614	0.580	0.749	
	LSE2	0.818						
	LSE3	0.798						
	LSE4	0.737						
	LSE5	0.769						
Organizational Culture	OC1	0.778	0.762	0.849	0.585	0.745	0.533	0.540
	OC2	0.782						
	OC3	0.685						
	OC4	0.809						

Notes: CA=Cronbach Alpha CR=Composite Reliability AVE=Average Variance Extracted

Structural Model

In this research, the assessment of the structural model followed the methodology outlined by Hair et al (2017), which involved a detailed examination of pathway coefficients (β) and coefficients of determination (R^2). To accomplish this, the Partial Least Squares (PLS) method was utilized, utilizing 5000 sub-samples to determine the significance level of path coefficients. The findings from hypothesis testing, including confidence intervals, covering path coefficients (beta), corresponding t-statistics, and p-values, are meticulously outlined in Table 3. This thorough investigation provides valuable insights into the significance and reliability of the relationships among the variables within the structural model. The detailed results of hypotheses testing presented in Table 5 offer a nuanced analysis of each hypothesis,

highlighting Beta coefficients, T-statistics, P-values, and the final determinations regarding hypothesis support, thereby enriching the depth and clarity of the study's conclusions.

The analysis of the hypotheses in Table 3, reveals several significant findings. *H1* proposes a direct positive relationship between a leader's engagement and leadership performance, which is supported by the data with a beta coefficient of 0.219, a t-statistic of 3.823, and a p-value of 0.000, indicating a highly significant effect. This suggests that leaders who are more engaged in their roles are likely to exhibit better leadership performance in open online flexible distance learning higher education institutions. *H2* examines the influence of a leader's engagement on a leader's self-efficacy, and the results confirm a strong positive relationship with a beta of 0.378, a t-statistic of 6.430, and a p-value of 0.000. This finding implies that leaders who are more engaged in their work are more likely to have higher levels of self-efficacy, which is their belief in their ability to lead effectively. *H3* tests the indirect effect of a leader's engagement on leadership performance through the mediating role of a leader's self-efficacy. The results support this hypothesis, with a beta of 0.181, a t-statistic of 5.090, and a p-value of 0.000. This suggests that a leader's self-efficacy partially mediates the relationship between a leader's engagement and leadership performance, meaning that engaged leaders who have higher self-efficacy are more likely to perform better in their roles. *H4* proposes a direct positive relationship between organizational culture and leadership performance, but this hypothesis is rejected based on the results, which show a beta of 0.081, a t-statistic of 1.415, and a p-value of 0.157. This indicates that organizational culture does not have a significant direct effect on leadership performance in the context of open online flexible distance-learning higher education institutions. *H5* examines the influence of organizational culture on a leader's self-efficacy, and the results support this hypothesis with a beta of 0.210, a t-statistic of 3.607, and a p-value of 0.000. This finding suggests that leaders who work in organizations with a strong, positive culture are more likely to have higher levels of self-efficacy. *H6* tests the direct effect of a leader's self-efficacy on leadership performance, and the results strongly support this hypothesis with a beta of 0.479, a t-statistic of 9.437, and a p-value of 0.000. This indicates that leaders with higher levels of self-efficacy are more likely to perform better in their roles, regardless of their level of engagement or the organizational culture. Finally, *H7* examines the indirect effect of organizational culture on leadership performance through the mediating role of a leader's self-efficacy. The results support this hypothesis with a beta of 0.100, a t-statistic of 3.301, and a p-value of 0.001. This suggests that a leader's self-efficacy partially mediates the relationship between organizational culture and leadership performance, meaning that leaders who work in organizations with a strong, positive culture and have higher self-efficacy are more likely to perform better in their roles.

Table 3

Hypotheses Testing Results

Hypotheses	Beta	T-statistics	P-values	2.50%	97.50%	Decision
<i>H1</i> : LE -> LP	0.219	3.823	0.000	0.111	0.336	<i>Accepted</i>
<i>H2</i> : LE -> LSE	0.378	6.430	0.000	0.251	0.483	<i>Accepted</i>
<i>H3</i> : LE -> LSE -> LP	0.181	5.090	0.000	0.114	0.251	<i>Accepted</i>
<i>H4</i> : OC -> LP	0.081	1.415	0.157	-0.029	0.195	<i>Rejected</i>
<i>H5</i> : LOC -> LSE	0.210	3.607	0.000	0.096	0.322	<i>Accepted</i>
<i>H6</i> : LSE -> LP	0.479	9.437	0.000	0.376	0.576	<i>Accepted</i>
<i>H7</i> : OC -> LSE -> LP	0.100	3.301	0.001	0.045	0.162	<i>Accepted</i>

Notes: significance $p \leq 0.05$

Table 4 provides a comprehensive summary of effect sizes (f^2), evaluated independently of sample size, according to Cohen's criteria (1992): small (0.020 to 0.150), medium (0.150 to 0.350), or large (0.350 or greater). The observed effect sizes ranged from small (0.007) to large (0.298). Intrinsic Value Inflation Factor (VIF) values, as outlined in Table 5, remained below the more lenient threshold of 5, with the highest value recorded at 1.792. This level of collinearity facilitates meaningful comparisons of sizes and interpretation of coefficients within the structural model. A noteworthy degree of explained variance for the endogenous construct is apparent, with an R^2 value of 0.447 (Figure 1). Regarding the mediator, the model explained approximately 28.3% of the variance in the structure, as indicated by an R^2 value of 0.283.

Table 4

Effect Sizes(f^2) & Variance Inflation Factor (VIF)

	f^2		VIF	
	LP	LSE	LP	LSE
LE	0.048	0.125	1.792	1.593
LSE	0.298		1.395	
OC	0.007	0.038	1.654	1.593

The model's inference and managerial recommendations were assessed through out-of-sample predictive analysis using the PLSpredict method (Shmueli et al., 2016, 2019). Table 5 demonstrates that PLS-SEM yielded superior Q^2 predictions (>0) compared to naive mean predictions, consistently displaying lower RMSE values than linear model (LM) benchmarks, thus highlighting its predictive accuracy. Additionally, the RMSE values for PLS-SEM predictions consistently surpassed those of the linear model (LM) prediction benchmark in six out of nine instances, emphasizing the predictive capability of the proposed model as outlined in Table 6. The introduction of the Cross-Validated Predictive Ability Test (CVPAT) by Hair et al. (2022), along with its integration with PLSpredict analysis by Liengard et al. (2021), is notable. Table 6 reaffirms the superior predictive performance of PLS-SEM, with lower average loss values compared to indicator averages and LM benchmarks, providing further confirmation of its enhanced predictive prowess.

Table 5

PLS Predicts

Indicators	Q^2 predict	PLS-RMSE	LM-RMSE	PLS-LM
LP1	0.236	0.634	0.639	-0.005
LP2	0.178	0.627	0.636	-0.009
LP3	0.180	0.696	0.694	0.002
LP4	0.070	0.751	0.751	0.000
LSE1	0.208	0.630	0.630	0.000
LSE2	0.182	0.627	0.635	-0.008
LSE3	0.126	0.677	0.683	-0.006
LSE4	0.136	0.688	0.697	-0.009
LSE5	0.159	0.625	0.628	-0.003

Table 6

Cross-Validated Predictive Ability Test (CVPAT)

	Average loss difference	t-value	p-value
LP	-0.090	4.632	0.000
LSE	-0.081	4.200	0.000
Overall	-0.085	5.056	0.000

Ringle and Sarstedt (2016) as well as Hair et al (2018) introduced Importance Performance Map Analysis (IPMA) to assess the significance and effectiveness of latent variables in elucidating acceptance, as detailed in Table 8. The overall impact on performance was most notable for leader self-efficacy (0.479), followed by leader engagement (0.400), underscoring their relative importance in performance. Organizational culture registered the highest score (66.509), while leader self-efficacy attained the lowest score (60.503) on a 0-100 scale, indicating superior performance for organizational culture and comparatively lower achievement for leader self-efficacy. Despite ranking first in leader performance importance, leader self-efficacy exhibited the lowest performance. These findings imply the need to prioritize strategies aimed at enhancing leader self-efficacy among leaders, potentially augmenting the overall performance of leaders in open online distance learning higher education institutions.

Table 7

Importance -Performance Map Analysis

Constructs	Total Effect	Performance
LE	0.400	66.339
LSE	0.479	60.503
OC	0.182	66.509

Discussion

In open online flexible distance learning higher education institutions, cultivating an effective organizational culture and bolstering leader engagement emerge as pivotal endeavors in elevating leadership performance. These institutions, often operating within dynamic and diverse landscapes, demand adaptable leadership and a nurturing culture to adeptly maneuver challenges and attain success. Central to this process is a leader's self-efficacy, which serves as a crucial mediator, shaping how leaders interpret and respond to organizational culture and engagement initiatives. Encouraging transparency and fostering robust communication channels stand out as paramount strategies for nurturing an effective organizational culture. Through open lines of communication, leaders can disseminate the institution's vision, values, and expectations to staff and students, fostering a profound sense of belonging and alignment. Creating avenues for feedback and dialogue further strengthens trust within the organization, allowing concerns to be addressed promptly and building a foundation of mutual respect. Moreover, accentuating shared goals and fostering collaboration reinforces a culture of teamwork and solidarity, amplifying organizational effectiveness. Leader engagement emerges as a linchpin in propelling organizational culture and performance forward. Engaged leaders, characterized by their passion, dedication, and enthusiasm, serve as beacons, inspiring others to pursue excellence. Leading by example, actively participating in initiatives, and demonstrating empathy toward the needs of staff and students are imperative facets of effective leadership. Engaging with stakeholders provides

leaders with invaluable insights into the institution's challenges and opportunities, facilitating informed decision-making and proficient problem-solving. Investing in leadership development initiatives further bolsters leaders' self-efficacy, equipping them with the requisite skills and confidence to navigate complex situations adeptly. Comprehensive programs encompassing communication skills, conflict resolution, adaptive leadership, and emotional intelligence fortify leaders' capabilities, enabling them to thrive in their roles. Moreover, facilitating mentorship or coaching opportunities affords leaders guidance and support, fostering continual growth and augmenting their leadership effectiveness. In essence, in the realm of open online flexible distance learning higher education institutions, fostering an effective organizational culture and nurturing leader engagement stand as imperatives, pivotal in enhancing leadership performance and propelling institutions towards their goals.

Theoretical Implications

The theoretical implications of the study examining the direct and indirect relationships between organizational culture, leader's engagement, leader's performance, and the mediating role of leader's self-efficacy in open online flexible distance learning higher education institutions are multifaceted and significant. This study is underpinned by the Transformational Leadership Theory Bass & Riggio (2006), which provides a robust framework for understanding how organizational culture and leader engagement influence leadership performance, with a leader's self-efficacy acting as a mediator. Transformational leadership, characterized by inspirational motivation, intellectual stimulation, individualized consideration, and idealized influence, underscores the importance of leaders fostering a positive organizational culture that encourages innovation, collaboration, and goal attainment (Burns, 2012). This aligns closely with the study's focus on exploring how leaders can shape organizational culture and enhance their engagement to improve leadership performance in the context of higher education institutions. The relationship between leadership engagement and performance is intricately linked to a leader's self-efficacy, which refers to their belief in their ability to lead effectively. High self-efficacy leaders are more likely to exhibit engagement in their roles and demonstrate effective leadership behaviors, resulting in enhanced organizational performance (Rabiul et al., 2022; Ul Hassan & Ikramullah, 2024). Moreover, leaders with high self-efficacy are better equipped to inspire and motivate their followers, thereby fostering a positive work environment conducive to collective success (Seo & Kwon, 2020). Similarly, the connection between organizational culture, a leader's self-efficacy, and leadership performance underscores the vital role of a leader's self-efficacy as a mediator. A positive organizational culture that emphasizes collaboration, innovation, and achievement contributes to the development of high self-efficacy among leaders (Azeem & Hanoum, 2024). This, in turn, enables leaders to exhibit effective leadership behaviors and drive organizational performance (Supriyatna & Wulandari, 2023). Additionally, the mediating role of a leader's self-efficacy is particularly salient in higher education institutions, where leaders must navigate complex challenges and adapt to changing circumstances (Chughtai et al., 2023).

Practical Implications

The practical implications of the study on organizational culture, leader engagement, leader's self-efficacy, and leadership performance in open online flexible distance learning higher education institutions are profound and offer valuable insights for institutional leaders and

administrators. Firstly, understanding the pivotal role of organizational culture in shaping leadership effectiveness underscores the importance of fostering a positive and inclusive culture within these institutions. Leaders should actively promote collaboration, innovation, and goal alignment to create an environment conducive to effective leadership and organizational success. Secondly, recognizing the significance of leader engagement and self-efficacy highlights the need for targeted interventions aimed at enhancing leaders' confidence in their abilities and fostering their active involvement in institutional initiatives. Providing leadership development programs that focus on communication skills, conflict resolution, and emotional intelligence can empower leaders to navigate the complexities of distance learning environments more effectively. Moreover, the study emphasizes the importance of promoting transparency, communication, and feedback mechanisms to enhance leader-staff and leader-student relationships, thereby fostering trust, engagement, and alignment with institutional goals.

Contextual Implications

The contextual implications of the study on organizational culture, leader engagement, leader's self-efficacy, and leadership performance in open online flexible distance learning higher education institutions shed light on the unique challenges and opportunities present in this educational landscape. Firstly, the study underscores the importance of recognizing the dynamic nature of distance learning environments and the need for adaptable leadership approaches. Leaders must be equipped with the skills and strategies to navigate the complexities of online education, including managing virtual teams, leveraging technology effectively, and fostering a sense of community and belonging among remote learners. Secondly, the study highlights the significance of contextual factors, such as technological advancements, cultural diversity, and evolving educational trends, in shaping leadership dynamics within online learning institutions. Leaders must be attuned to these contextual nuances and tailor their approaches accordingly to ensure relevance and effectiveness. Moreover, the study underscores the importance of collaboration and knowledge sharing among institutions to address common challenges and capitalize on emerging opportunities in the field of online education. Leaders can benefit from networking opportunities, sharing best practices, and engaging in collaborative research to enhance their understanding of effective leadership in the context of distance learning.

Suggestions for Future Study

Building on the foundations laid by the current study, several avenues for future research emerge that could deepen our understanding of leadership dynamics in open online flexible distance-learning higher education institutions. Firstly, future studies could explore the role of specific leadership styles, such as transactional, laissez-faire, or authentic leadership, in influencing organizational culture, leader engagement, and performance in online learning environments. Investigating how different leadership approaches impact these outcomes could provide valuable insights for leaders seeking to optimize their leadership strategies in distance learning settings. Secondly, longitudinal studies could be conducted to examine the long-term effects of leadership development interventions on leader self-efficacy, engagement, and performance in online education institutions. Tracking the impact of leadership training programs over time could elucidate the sustainability and effectiveness of such interventions in fostering leadership excellence in distance learning contexts. Moreover, future research could explore the influence of external factors, such as regulatory changes,

technological advancements, or socio-economic trends, on leadership dynamics in online education institutions. Understanding how external forces shape leadership practices and organizational culture in distance learning settings could inform proactive strategies for institutional leaders to adapt and thrive in a rapidly changing landscape. Additionally, comparative studies could be conducted to explore cross-cultural variations in leadership practices and their implications for organizational culture, leader engagement, and performance in online learning environments. Examining how cultural differences influence leadership dynamics could provide valuable insights for leaders operating in diverse educational contexts.

Conclusion

This study has illuminated the intricate interplay between organizational culture, leader engagement, leader's self-efficacy, and leadership performance in open online flexible distance learning higher education institutions. Grounded in the Transformational Leadership Theory, the findings underscore the significance of fostering a positive organizational culture that promotes collaboration, innovation, and goal alignment to enhance leadership effectiveness. Moreover, the study highlights the pivotal role of leader engagement and self-efficacy as catalysts for driving organizational performance and fostering a conducive learning environment. Leaders equipped with high levels of self-efficacy are better positioned to inspire and motivate their followers, navigate complex challenges, and adapt to changing circumstances in online education settings. Furthermore, the study emphasizes the importance of contextually relevant leadership approaches tailored to the unique challenges and opportunities present in distance learning environments. Leaders must be equipped with the skills, strategies, and adaptive mindset necessary to thrive in this rapidly evolving educational landscape. Overall, the insights gleaned from this study offer valuable implications for leaders, administrators, and policymakers in open online flexible distance learning higher education institutions, providing a roadmap for fostering effective leadership, enhancing organizational culture, and driving institutional success in the digital age.

References

- Adu, J., & Nawangsari, L. C. (2022). Build Organizational Citizenship Behavior Toward Environment Through Organizational Culture, Organizational Commitment and Mediated Self-efficacy. *International Journal of Indonesian Business Review*, 1(1), 80-89.
- Afrifa Jr, S., Fianko, S. K., Amoah, N., & Dzogbewu, T. C. (2022). The Effect of Organizational Culture on Employee Work Engagement in a Higher Education Institution. *Organizational Cultures: An International Journal*, 22(2).
- Akanji, B., Mordi, C., Ituma, A., Adisa, T. A., & Ajonbadi, H. (2020). The influence of organisational culture on leadership style in higher education institutions. *Personnel Review*, 49(3), 709-732.
- Ashfaq, F., Abid, G., & Ilyas, S. (2021). Impact of ethical leadership on employee engagement: role of self-efficacy and organizational commitment. *European Journal of Investigation in Health, Psychology and Education*, 11(3), 962-974.
- Azeem, R. A. C., & Hanoum, S. (2024). Analyzing the Impact of Creative Self-Efficacy, Leadership Style, Locus of Control, and Organizational Culture on Innovative Work Behavior and Employee Performance. *Journal La Sociale*, 5(2), 518-530.
- Bass, B. M. (1999). Two decades of research and development in transformational

- leadership. *European journal of work and organizational psychology*, 8(1), 9-32.
- Bass, B. M., & Riggio, R. E. (2006). *Transformational leadership* (2nd ed.). Lawrence Erlbaum Associates Publishers. <https://doi.org/10.4324/9781410617095>
- Bobbio, A., & Manganello, A. M. (2009). Leadership self-efficacy scale: A new multidimensional instrument. *TPM-Testing, Psychometrics, Methodology in Applied Psychology*, 16(1), 3-24
- Bratton, J., & Gold, J. (2017). *Human resource management: theory and practice*. London, UK: Palgrave Macmillan.
- Burns, J. M. (2012). *Leadership*. Open Road Media.
- Chughtai, M. S., Syed, F., Naseer, S., & Chinchilla, N. (2023). Role of adaptive leadership in learning organizations to boost organizational innovations with change self-efficacy. *Current Psychology*, 1-20.
- Hair, J. F., Hult, G. T. M., Ringle, C. M., & Sarstedt, M. (2017). *A primer on partial least squares structural equation modeling (PLS-SEM)* (2nd ed.). Thousand Oaks, CA: SAGE.
- Hair, J. F., Sarstedt, M., Ringle, C. M., and Gudergan, S. P. (2018). *Advanced issues in partial least squares structural equation modeling*. Thousand Oakes, CA: Sage Publications
- Hair, J. F., Hult, G. T. M., Ringle, C. M., & Sarstedt, M. (2022). *A Primer on Partial Least Squares Structural Equation Modeling (PLS-SEM)* (3 ed.). Thousand Oaks, CA: Sage.
- Henseler, J., Ringle, C. M., and Sarstedt, M. (2015). A new criterion for assessing discriminant validity in variance-based structural equation modeling, *Journal of the Academy of Marketing Science*, 43(1): 115-135.
- Hidayat, D., Maitimo, V. V., & Suwu, S. E. (2020). Increasing teachers' work engagement through servant leadership, organizational culture, and job satisfaction. *Jurnal pendidikan dan Pengajaran*, 53(1), 90-100.
- Insan, A., & Masmarulan, R. (2021). Effects of leader-member exchange and organizational culture on work engagement and employee performance. *Management Science Letters*, 11(3), 879-886.
- Kebah, M., Raju, V., & Osman, Z. (2019). Growth of online purchase in Saudi Arabia retail industry. *International Journal of Recent Technology and Engineering*, 8(3), 869-872.. ISSN: 2277-3878
- Kebah, M., Raju, V., & Osman, Z. (2019). Online purchasing trend in the retail industry in Saudi. *International Journal of Recent Technology and Engineering (IJRTE)*, 8(3), 865-868. ISSN: 2277-3878
- Khan, M. A., Ismail, F. B., Hussain, A., & Alghazali, B. (2020). The interplay of leadership styles, innovative work behavior, organizational culture, and organizational citizenship behavior. *Sage Open*, 10(1), 2158244019898264.
- Kock, N., & Lynn, G. S. (2012). Lateral collinearity and misleading results in variance-based SEM: An illustration and recommendations. *Journal of the Association for Information Systems*, 13(7), 546-580.
- Kock, N. (2015). Common method bias in PLS-SEM: A full collinearity assessment approach. *International Journal of e-Collaboration*, 11(4), 1-10.
- Lasrado, F., & Kassem, R. (2021). Let's get everyone involved! The effects of transformational leadership and organizational culture on organizational excellence. *International Journal of Quality & Reliability Management*, 38(1), 169-194.

- Li, X. T., Rahman, A., Connie, G., & Osman, Z. (2020). Examining customers' perception of electronic shopping mall's e-service quality. *International Journal of Services, Economics and Management*, 11(4), 329-346.
- Lienggaard, B. D., Sharma, P. N., Hult, G. T. M., Jensen, M. B., Sarstedt, M., Hair, J. F., & Ringle, C. M. (2021). Prediction: Coveted, Yet Forsaken? Introducing a Cross-validated Predictive Ability Test in Partial Least Squares Path Modeling. *Decision Sciences*, 52(2), 362-392.
- Liou, Y. H., & Daly, A. J. (2020). Investigating leader self-efficacy through policy engagement and social network position. *Educational policy*, 34(3), 411-448.
- Kaur, M. J. S., & Poh, P. S. (2022). The influence of leadership style on employee engagement. *Journal of Business and Social Sciences*, 2022(08), 1-30.
- Meria, L., Prastyani, D., & Dudhat, A. (2022). The role of transformational leadership and self-efficacy on readiness to change through work engagement. *Aptisi Transactions on Technopreneurship (ATT)*, 4(1), 77-88.
- Mulyanti, R., Saepudin, T. H., & Aviyanti, C. (2023). Model of Leadership Style, Self-Efficacy, on Performance and Work Engagement as an Intervening Variable: A Literature Review. *Dinasti International Journal of Management Science*, 5(1), 142-158.
- Nwannah, N. C., Adebusuyi, J. R., Ayodele, K. O., Ezeokoli, R. N., Morka, E., & Eregare, E. O. (2022). The predictive power of leadership behaviour, organisational culture and work engagement on knowledge management in academia. *Journal of Positive School Psychology*, 6(8), 5918-5928.
- Osman, Z., Mohamad, W., Mohamad, R. K., Mohamad, L., & Sulaiman, T. F. T. (2018). Enhancing students' academic performance in Malaysian online distance learning institutions. *Asia Pacific Journal of Educators and Education*, 33, 19-28.
- Pratiwi, L. A., & Nawangsari, L. C. (2021). Organizational citizenship behavior while mediating self-efficacy, servant leadership and organization culture on employee performance. *European Journal of Business and Management Research*, 6(1), 225-231.
- Rabiul, M. K., Patwary, A. K., & Panha, I. M. (2022). The role of servant leadership, self-efficacy, high performance work systems, and work engagement in increasing service-oriented behavior. *Journal of Hospitality Marketing & Management*, 31(4), 504-526.
- Ringle, C. M., and Sarstedt, M. (2016). Gain more insight from your PLS-SEM results: The importance-performance map analysis. *Industrial Management & Data Systems*. 116: 1865–1886.
- Rohman, A. F., Indiyati, D., & Ghina, A. (2021). The Influence of Organizational Culture and Employee Engagement on Employees Performance at Telkom University, Indonesia. *International Journal of Science and Society*, 3(1), 75-88.
- Seo, J., & Kwon, H. (2020). The Effect of Empowering Leadership on Work Engagement and Job Performance through Employees' Self-Efficacy and Belonging. *Journal of the Korea Industrial Information Systems Research*, 25(5), 103-117.
- Shmueli, G., Sarstedt, M., Hair, J. F., Cheah, J.-H., Ting, H., Vaithilingam, S., and Ringle, C. M. (2019). Predictive model assessment in PLS-SEM: Guidelines for using PLSpredict. *European Journal of Marketing*. 53: 2322–2347.
- Srimulyani, V. A., & Hermanto, Y. B. (2022). Organizational culture as a mediator of credible leadership influence on work engagement: empirical studies in private hospitals in East Java, Indonesia. *Humanities and Social Sciences Communications*, 9(1), 1-11.
- Supriyatna, S., Kadar, I., & Wulandari, D. (2023). Strengthening Organizational Culture,

- Transformational Leadership, Self-Efficacy, and Achievement Motivation in Increasing Innovation Efforts. *International Journal of Social Health*, 2(5), 202-216.
- Tyagi, N. (2021). Aligning organizational culture to enhance managerial effectiveness of academic leaders: an interface for employee engagement and retention. *International Journal of Educational Management*, 35(7), 1387-1404.
- Ul Hassan, F. S., & Ikramullah, M. (2024). Transformational leadership and employees' work engagement: the simple and parallel mediation of self-efficacy and trust in the leader. *Journal of Organizational Effectiveness: People and Performance*, 11(2), 448-465.
- Van den Berg, P. T., & Wilderom, C. P. M. (2004). Defining, Measuring, and Comparing Organisational Cultures. *Applied psychology*, 53(4), 570-582. <https://doi.org/10.1111/j.1464-0597.2004.00189.x>
- Wonodhipo, A. R., Hardhienata, S., & Tukiran, M. (2024). Improving Employee Performance Through Strengthening Organizational Culture, Visionary Leadership, Self-Efficacy, And Job Satisfaction: Empirical Studies on Training Participants at Center for Development of Vocational Education Quality Assurance in Busin. *OPSearch: American Journal of Open Research*, 3(2), 885-896.
- Wu, M. C., Chiang, W. J., Chiang, S. L., Trung, P. M., & Lindayani, L. (2023). A study on major factors revitalizing nursing staff's work enthusiasm~ a cross-national study on organizational culture, organizational empowerment and self-efficacy. *International Journal of Healthcare Management*, 16(1), 93-103.
- Zeeshan, S., Ng, S. I., Ho, J. A., & Jantan, A. H. (2021). Assessing the impact of servant leadership on employee engagement through the mediating role of self-efficacy in the Pakistani banking sector. *Cogent Business & Management*, 8(1), 1963029.